

Eclipse ThermJet Burners

for Preheated Combustion Air

Model TJPCA1000

Version 2

Parameter			Specifications		
			Natural Gas	Propane	Butane
Maximum Input BTU/hr (kW)			10,000,000 (2930)	10,000,000 (2930)	10,000,000 (2930)
Minimum Input, On-Ratio BTU/hr (kW)			1,000,000 (293)	1,000,000 (293)	1,000,000 (293)
Gas Inlet Pressure Required "w.c. (mbar) Fuel Pressure at Gas Inlet <i>(Tap "B" - see page 3)</i>	Combustion Air Temp	Ambient	5.5 (13.7)	5.5 (13.7)	5.5 (13.7)
		300°F (150°C)	7.1 (17.7)	7.1 (17.7)	7.1 (17.7)
		700°F (370°C)	10.1 (25.1)	10.1 (25.1)	10.1 (25.1)
		1000°F (540°C)	-	-	-
Air Inlet Pressure Required "w.c. (mbar) 15% Excess Air at Maximum Input <i>(Tap "A" - see page 3)</i>	Combustion Air Temp	Ambient	4.0 (10.0)	4.0 (10.0)	4.0 (10.0)
		300°F (150°C)	5.6 (13.9)	5.6 (13.9)	5.6 (13.9)
		700°F (370°C)	8.6 (21.4)	8.6 (21.4)	8.6 (21.4)
		1000°F (540°C)	-	-	-
High Fire Flame Length Inches (mm) <i>(Measured from End of Combustor)</i>			<149.0 (3785)	<149.0 (3785)	<154.0 (3912)
Flame Detection			UV scanner available for all combustors.		
Fuel <i>For any other mixed gas, contact Eclipse for orifice sizing.</i>			Natural gas, propane, or butane.		

- All information is based on laboratory testing in neutral (0.0" w.c.) pressure chamber. Different chamber size and conditions may affect the data.
- All information is based on standard combustor design. Changes in combustor will alter performance and pressures.
- All inputs based upon gross calorific values.
- Eclipse reserves the right to change the construction and/or configuration of our products at any time without being obliged to adjust earlier supplies accordingly.
- Plumbing of air and gas will affect accuracy of orifice readings. All information is based on generally acceptable air and gas piping practices.

Performance Graphs

Ignition & Operational Zones

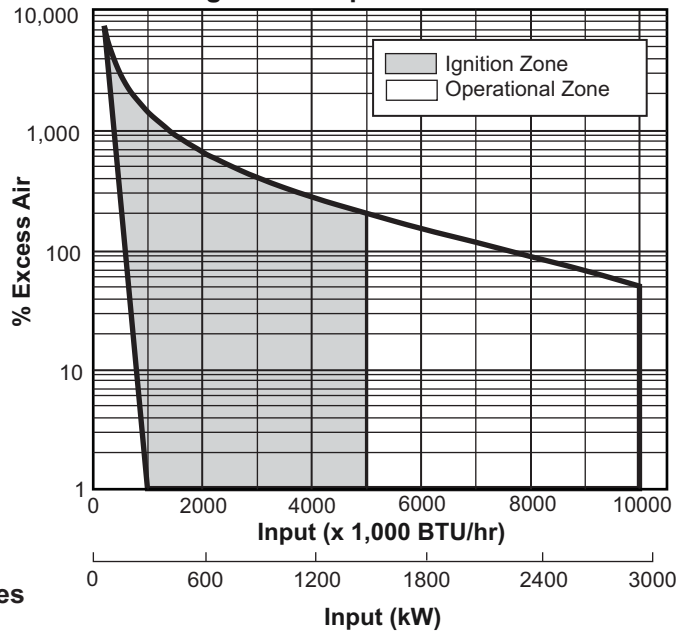

NO_x vs Preheated Air Temperatures (Based on Maximum Firing Rate)

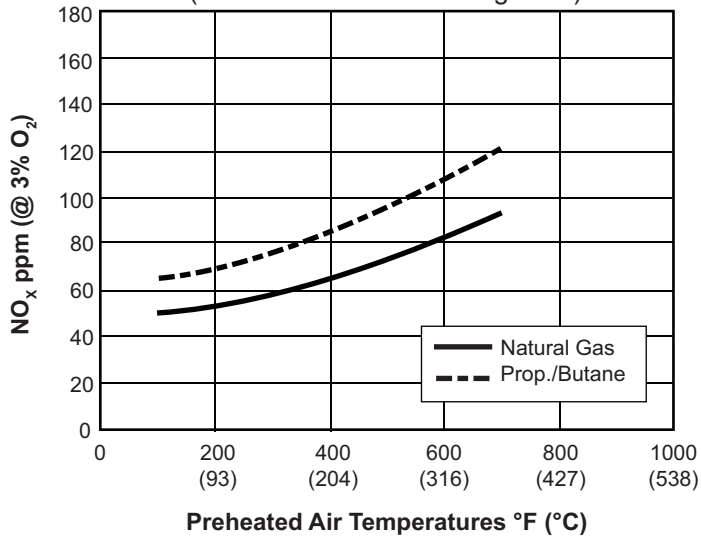

Emissions from the burner are influenced by:

- Fuel type
- Combustion air temperature
- Firing rate
- Chamber conditions
- Percent of excess air

For estimates of other emissions, contact Eclipse.

Gas Orifice ΔP vs. Input (Measured from Tap B to Tap D)

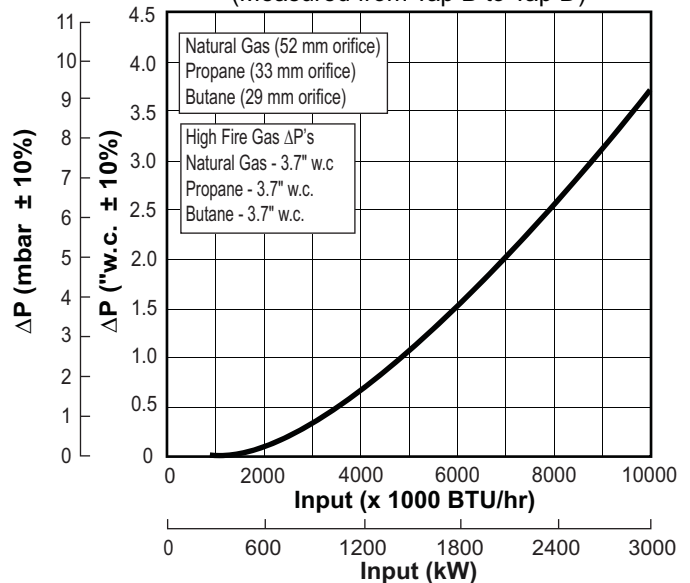

Dimensions in inches (mm)

Burner Housing

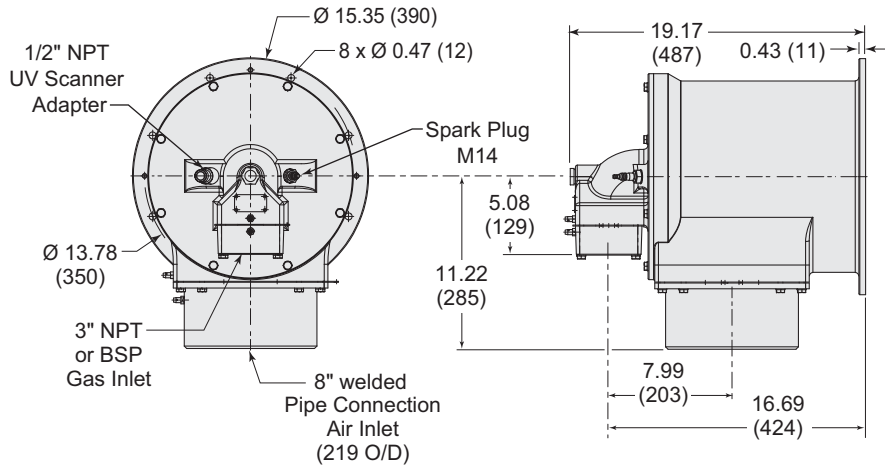

Tap Locations

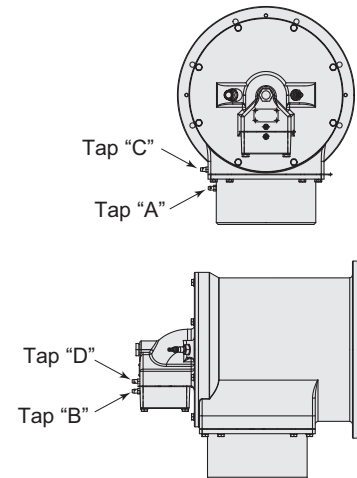

Burner weight less combustor: 133 lbs (60 kg)

Combustor

Exhaust Outlet Diameter - Medium Velocity: Ø 9.84 (250)

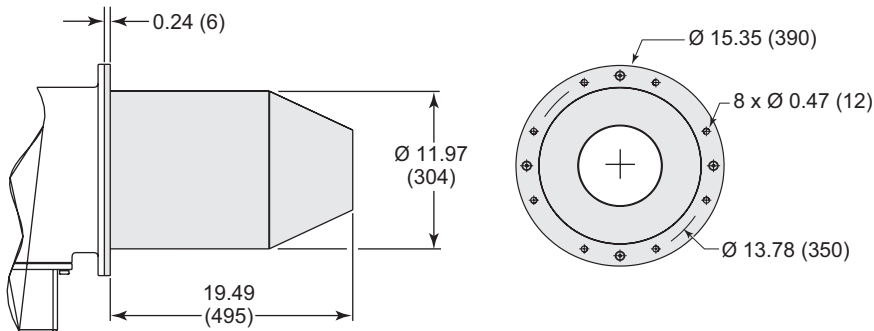

Alloy Tube (AISI 310)

Weight: 21 lbs (9.5 kg)
Max. Chamber Temp: 1,750°F (950°C)
(Not suitable for preheated air over 700°F)

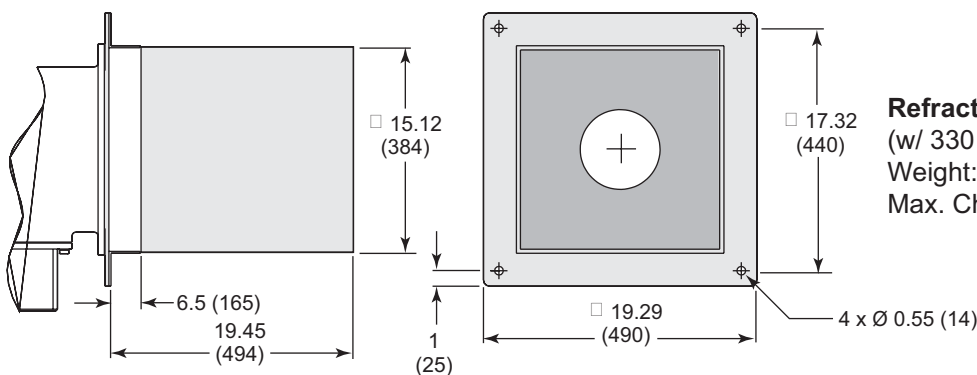

Refractory Block

(w/ 330 SS wrapper)
Weight: 310 lbs (141 kg)
Max. Chamber Temp: 2,800° (1535°C)

Down Firing Block

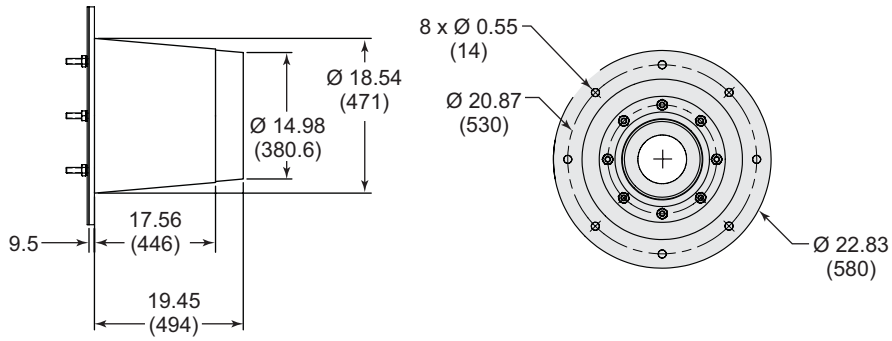

Weight: 290 lbs (131.54 kg)
Max. Chamber Temp: 2800°F (1535°C)



Offered By:

Power Equipment Company
2011 Williamsburg Road
Richmond, Virginia 23231
Phone (804) 236-3800
Fax (804) 236-3882

www.peconet.com